

Darich Homes (Northants) Ltd
6 Alfred St
Rushden
Northamptonshire
NN10 9YS

CONTACT
Andy Bailey
Area Sales Manager - Concrete
+44 (0)7876 897250
bailey.andy@uk.sika.com

22nd December 2020

Reference: bailey.andy-2020-023

RE: Plot 2 - 3, Greenacre Drive, Rushden

For the attention of Richard Abbott

Dear Richard Abbott

Regarding our recent discussions about the Green Acre Drive project in Rushden, please see the following specifications for our SikaProof A and P membrane, Sika watertight concrete and Sikaswell water stops.

The waterproofing strategy is based on combined protection (Grade 3 BS8102) and is covered by Sika's 20 year performance warranty. It is advised that external, maintainable drainage should also be provided around the basement perimeter.

At the time of writing we have not based this specification on the presence of ground gases.

Please see typical sections provided by Sika that illustrate the detailing of our products.

Further to our discussions on the 21 December 2020, this document has been compiled for your attention by Andy Bailey of Sika Limited. It is based on the information gathered during recent discussions and is intended to provide details relating to the treatment of the semi retained basement areas in question. The document includes material specifications and if you require NBS specifications a link to our standard NBS specifications can be found in the project related documentation section towards to end of the document.

Sika Limited, the UK subsidiary of the worldwide Sika Group was established in 1927 and produces and markets a wide range of state-of-the-art systems. This activity is underpinned by unrivalled innovation in product development, the highest standards of manufacturing and renowned technical advice and in-situ guidance. A fully integrated service is provided for end users or their specifiers, be they clients, designers, engineers, producers, distributors, merchants and contractors.

Within the UK, as in all other group locations, Sika operates to optimal levels of performance, demonstrated through possession of EN ISO 9001 certification for quality control and EN ISO 14001 for environmental management. Wherever possible products are manufactured to European and British Standards, are approved by the British Board of Agrément or provide unique and superior properties.

Sika Limited is an active member of many organisations and bodies relevant to our target markets.

Sika Limited has achieved the Silver level of recognition for our Supply Chain Sustainability School membership.

The reputation for Sika for quality and reliability is virtually unmatched, illustrated through a comprehensive portfolio of problem solving products that have been employed for many years in wide diversity of applications.

SIKA LIMITED SERVICES

Sika Limited offers the following services:

Detailed assessment of project and performance criteria together with production of Sika product proposals and specification clauses for inclusion within contract documents.

Recommendation of contractors who are under constant review for the installation of Sika products.

Complete material data, installation guidelines, health and safety information and, where appropriate maintenance schedules, in either electronic or hard copy for pre-contract and post-contract use.

Registered schooling of company and customer staff in the application of our products and systems, together with continuous product training for client, consultant and contractor representatives.

Dedicated personnel assigned to projects where select Sika materials are employed in order to monitor and ensure correct application prior to issue of site observations, guarantees or performance liability statements.

After sales support in the form of in-situ advice once works are due to commence or are underway, thus maintaining a partnership from concept through to completion stages.

This specification should be read in conjunction with the relevant product data sheets and all named appendices.

This specification is valid for a period of 12 months, after which it should be reviewed to ensure that the suggested solutions are still fit for purpose.

Any variations to this specification must be confirmed by Sika Limited to ensure the suitability of the proposed change and any impact this may have on guarantees offered or implied. As part of Sika Limited's continuous product development, we retain the right to alter our product specifications in accordance with relevant national and international standards without notice.

We understand the project is a semi retained basement structure which will be constructed from In situ cast concrete.

We have been informed that you require a Grade 3 environment according with BS8102:2009 - Code of practice for protection of below ground structures against water from the ground.

BS8102:2009 recommends in Table 1 that for a Grade 3 basement that two forms of waterproofing are considered to help reduce risk. In addition a number of building warranty providers such as NHBC, LABC and Premier Guarantee are now insisting on two forms of waterproofing known as dual systems for Grade 3 environments and in some instances Grade 2 environments.

At this time site investigation information is not available, we recommend that this is carried out in accordance with the standards, and the information is provided to Sika Limited at a later date to ensure the specification is still valid.

SIKA LIMITED

Head Office · Watchmead · Welwyn Garden City · AL7 1BQ · United Kingdom

Phone: +44 1707 394444 · Fax: +44 1707 329129 · www.sika.co.uk · Registered in England and Wales 226822

We are informed the water table is yet to be confirmed. It is considered good practice in accordance with BS8102:2009 that all future eventualities are considered including rise in water table due to environmental and social changes within the area. BS8102:2009 section 6.1 states "waterproofing measures should be designed on the basis of water to the full height of the retained ground at some life during the structures life". We therefore recommend the waterproofing is designed to full height of the basement structure.

We trust this is of assistance to you. If we can be of further help on this, or any other project, please do not hesitate to contact me on +44 (0)7876 897250 or by email at bailey.andy@uk.sika.com.

Kind regards



Andy Bailey
Area Sales Manager - Concrete

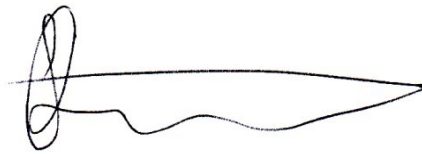

Stephen Armfield
Product Manager - Waterproofing

PROJECT PROPOSAL



DARICH HOMES (NORTHANTS) LTD - RUSHDEN

PROJECT: PLOT 2 - 3, GREENACRE DRIVE, RUSHDEN

PROJECT REF: BAILEY.ANDY-2020-023

DATE: 22 DECEMBER 2020

CONTACT SHEET

Prepared for: Darich Homes (Northants) Ltd
6 Alfred St
Rushden
Northamptonshire
NN10 9YS

For the attention of: Richard Abbott
Email: darichltd@gmail.com

Site: Plot 2 - 3, Greenacre Drive, Rushden
Greenacre Drive
Rushden
Northamptonshire
NN10

Prepared by: Andy Bailey - Area Sales Manager - Concrete

Telephone: +44 (0)7876 897250

Email: bailey.andy@uk.sika.com

Site Technical Support: Scott Hawley

Telephone: +44 (0)1707 363875

Email: waterproofing@uk.sika.com

Date: 22 December 2020

CONTENTS

1. Specification - Plot 2 - 3 Basement	7
1.1 - System Schedule	7
1.2 - Solution Intro	8
1.3 - Specifications	9
1.4 - Sample Guarantee	25
2 Appendices	28
2.1 Disclaimer	28
2.2 Drawings	28
2.3 Project Related Documentation	28

1. SPECIFICATION - PLOT 2 - 3 BASEMENT

1.1 - SYSTEM SCHEDULE

AREA	MATERIAL
Project Type	New
BS8102:2009 Type	Type A Type B
BS8102:2009 Grade	Grade 3
Additional Permeability Requirements	No Gas Specification Required
Solution(s)	Sika Watertight Concrete Powder SikaProof A08 SikaProof P12 Sika Drain 850 Geo
Construction Jointing	SikaSwell A Sika Metal Waterbar
Movement Jointing	No movement joints specified

The following specification is to be read in conjunction with the project condition report, drawings and project specific documentation where included, and all points should be considered as part of the scope of works.

1.2 - SOLUTION INTRO

First used in the UK over 60 years ago, the Sika® Watertight Concrete system has constantly evolved to utilize the latest admixture technology and to suit changes in cement chemistry, the increased use of replacement materials (GGBS, PFA) and the wide range of aggregate types used.

Due to the benefits the Sika® Watertight Concrete system offers it is now the most widely used system of its type in the UK.

Sika Watertight concrete can be used as the primary waterproofing system or as part of a combined waterproofing strategy (see BS8102:2009) alongside SikaProof, Sika Cavity Drain or other appropriate Sika waterproofing solutions.

Sika Watertight concrete range includes Sika Watertight Powder, Sika 1+ and Sika WT-200P.

SikaProof® A is a pre-applied fully bonded membrane system with superior durability, crack bridging ability and stress crack resistance. SikaProof® A complies with BS8102:2009 Type A waterproofing and can also be used as part of a dual system waterproofing strategy alongside other appropriate Sika waterproofing solutions such as Sika Watertight Concrete or Sika Cavity Drain.

Due to its flexibility, SikaProof® A installation is quick and simple; internal and external corners and penetrations etc are easy to detail with the minimum of ancillary products needed. The membrane is available in 1m or 2m wide rolls which means reduced waste and potentially fewer laps and joints.

Because SikaProof® A is supplied globally it has been tested to all relevant international Standards. Uniquely, all Standard connections with ancillary products such as taped joints, penetration details and pile head details have also been tested so you can be sure the system works, not just the individual components.

As part of the SikaProof system a post applied version, SikaProof P, is available where construction sequences dictate a pre applied membrane would not be practical. SikaProof P requires the substrate to be primed prior to installation with SikaProof Primer-01.

1.3 - SPECIFICATIONS

E10 MIXING/CASTING/CURING IN-SITU CONCRETE

To be read with Preliminaries / general conditions and the Sika Watertight Concrete Powder datasheet.

The details contained within this proposal are based on information available at the time of writing. It covers the installation of Sika materials and the preparation work necessary to provide a suitable substrate. Sika Limited cannot be held responsible for unknown site conditions or for the performance of materials within the system other than Sika products or Sika branded products.

A detailed method of work statement and programme of works should be agreed with the contractor before the commencement of the works.

The requirements of all relevant British Standards and Industry Codes of Practice should be complied with at all times.

PERFORMANCE

This specification is for a waterproofing Type B solution in accordance with BS8102:2009 with the design intent of preventing water migration into the below ground structure.

Performance must be as follows:

MANUFACTURER'S GUARANTEE

The waterproof concrete manufacturer is to provide a product guarantee that is for the benefit of the end user. This is to be a 15 year product guarantee for single waterproofing systems and a 20 year (15 year*) product guarantee when combined with a Type A or Type C solution in accordance with BS8102:2009 from the same manufacturer. All materials including detailing materials must be from a single source manufacturer.

The waterproof concrete manufacturer is to conduct comprehensive and regular inspections during the systems installation. Reports are to be presented to the contractor by the manufacturer.

The waterproof concrete manufacturer must have Professional Indemnity Insurance for the waterproofing scope of works to the basement and/or foundations where a product guarantee is required.

*product guarantee period when used in conjunction with Sika BentoShield

PRODUCT PERFORMANCE

Waterproof concrete system must be British Board of Agrément Certificated and CE marked

Waterproof concrete admixture must be supplied in 1.75kg soluble bags to allow easy application and quality control at the readymix concrete plant

Waterproof concrete system to consist of a combined water resisting hydrophobic pore blocking and HRWR/Superplasticising admixture.

All detailing materials, waterbars and ancillaries to be provided by a single source manufacturer.

CONCRETE

1.3 - Specifications continues overleaf...

101 SPECIFICATION

- Concrete Generally: To BS 8500-2.
- Exchange of information: Provide concrete producer with information required by BS 8500-1, clauses 4 and 5.

132 DESIGNED CONCRETE

- Embedded Metal: As required. The structural concrete element is to be designed in accordance with the flexural and thermal crack limitations of 0.3 mm as stated in BS EN 1992 Eurocode 2, or the limitations of 0.2 mm as stated in BS 8007.
- Compressive strength class (cylinder/cube minimum): C28/35
- Fibres: As required.
- Aggregates:
 - Type/Density: Dependant on local availability.
- Design chemical class: As appropriate for site conditions
- Aspect Ratio:
 - o Maximum 1:3 for >1m wall height
 - o Maximum 1:5 for <1m wall height
 - o Maximum slab area is 400m²
- Limiting values for composition:
 - Water/Cement Ratio (maximum): 0.45
 - Total Cementitious content (minimum): 350kg/m³
 - Total Cementitious content (maximum): 500kg/m³
 - Consistence class (minimum): S3 (BS EN 206)
 - Permitted cement/combinations: The product is compatible with cement blends containing pulverized-fuel ash, ground granulated blast furnace slag and silica fume blends as defined in BS EN 197-1 : 2011.
 - Admixtures: Sika Watertight Concrete Powder with SikaPlast, Sika Viscoflow OR Sika Viscocrete as required.

MATERIALS, BATCHING AND MIXING

215 READY-MIXED CONCRETE

- Production plant: Currently certified by QSRMC, BSI or equivalent
- Source of ready-mixed concrete: Obtain from one source if possible. Otherwise submit proposals.
 - Name and address of depot: Submit before any concrete is delivered.
 - Delivery notes: Retain for inspection.
- Declarations of nonconformity from concrete producer: Notify immediately.

230 INTERRUPTION OF SUPPLY DURING CONCRETING

- Elements without joints: Where elements are detailed to be cast in a single pour without joints, make prior arrangements for a back-up supply of concrete.
- Elsewhere :
 - Preparation: Manage pour to have a full face, and have materials available to form an emergency construction joint while concrete can still be worked.
 - Before pour is completed: Submit location and details of joint, make proposals for joint preparation.

1.3 - Specifications continues overleaf...

325 MATERIALS FOR EXPOSED VISUAL CONCRETE

- Alterations to sources, types and proportions: Submit proposals.

415 ADMIXTURES

- SikaPlast, Sika Viscoflow OR Sika Viscocrete as required
- Calcium chloride and admixtures containing calcium chloride: Do not use.
- Dosage rate shall be 1 x 1.75 kg bag per m³.

418 PROPRIETARY ADMIXTURE

- Type: Sika Watertight Concrete Powder
 - Manufacturer: Sika Limited, Watchmead, Welwyn Garden City, Hertfordshire, AL7 1BQ, 01707 394444.
 - Product reference: Sika Watertight Concrete Powder.

490 PROPERTIES OF FRESH CONCRETE

- Adjustments to suit construction process: Determine with concrete producer. Maintain conformity to the specification

PROJECT TESTING/CERTIFICATION

505 PROJECT TESTING OF CONCRETE-GENERAL

- Testing: BBA Certificate 08-4606
- Conforms to the requirements of BS EN 934-2 Table 9
- DoP 02 07 05 04 001 0 000012 1088, certified by Factory Production Control Body 0086, Certificate 541325, and provided with the CE mark
- Recording: Maintain complete correlated records including:
 - Concrete designation.
 - Sampling, site tests, and identification numbers of specimens tested in the laboratory.
 - Location of the parts of the structure represented by each sample.
 - Location in the structure of the batch from which each sample is taken.

PLACING/COMPACTING/CURING AND PROTECTING

620 TEMPERATURE OF THE CONCRETE

- Objective: Limit maximum temperature of concrete to minimize cracking during placing, compaction and curing. Take account of:
 - High temperature and steep temperature gradients: Prevent build-up during first 24 hours after casting. Prevent coincidence of maximum heat gain from cement hydration with high air temperature and/or solar gain.
 - Rapid changes in temperature: Prevent during the first seven days after casting.
- Proposals for meeting objective: Submit.

630 PREMATURE WATER LOSS

- Requirement: Prevent water loss from concrete laid on absorbent substrates.
 - Underlay: Select from:
 - Polyethylene sheet: 250 micrometres thick.
 - Building paper: To BS 1521, grade B1F.

1.3 - Specifications continues overleaf...

- Installation: Lap edges 150mm.

640 CONSTRUCTION JOINTS

- See section E40 for Sika Waterbar details.

645 SPACING OF CONSTRUCTION JOINTS

- Type of construction: Project dependant
 - Distance between joints (maximum): 1:3 for wall sections
 - Area of pour (maximum): 400m² for slab sections
 - Other requirements: Appropriate use of jointing projects. See NBS Clause E40

648 ADVERSE TEMPERATURE CONDITIONS

- Requirement: Submit proposals for protecting concrete when predicted ambient temperatures indicate risk of concrete freezing or overheating.

650 SURFACES TO RECEIVE CONCRETE

- Cleanliness of surfaces immediately before placing concrete: Clean with no debris, tying wire clippings, fastenings or free water.

660 INSPECTION OF SURFACES

- Notice: Give notice to allow inspections of reinforcement and surfaces before each pour of concrete.
- Watertight Concrete Site Attendance Procedure Guidelines:
 - This document is meant as a guide to inform customers of our site attendance service. Please note that site attendance does not constitute supervision.
 - A successful project is a result of Sika and the contractor working together.
 - Note: Sika Site attendance is necessary to qualify for our performance warranty and is free of charge to contractors using the Sika watertight concrete system. This will be in the form of our Sika waterproofing technician or member of staff.
- Planning
 - A planning meeting should be held with the site management and, if needed, the design team to discuss:
 - Programme
 - Check mix design certificates provided by the ready-mix supplier
 - Concrete consistence requirements (liaise with premix supplier)
 - Pour sequences and aspect ratios
 - Joint layout and appropriate Sika solution
 - Service entry points and appropriate Sika solution
 - Person(s) to be main points of contact between Sika and site
 - 48 hours' notice is required to ensure site attendance of a Sika Waterproofing team member
- Tool Box Talks
- Before concrete works commence on site, the following should be covered with site staff and a Sika operative:
 - General concrete practice: placing, compaction and curing methods.
 - Substrate preparation: Joint rebates, surface retarders, scabbling
 - Joint system installation including a physical demonstration
 - Detailing of penetrations and tie holes

1.3 - Specifications continues overleaf...

- Note: Only site personnel who have received a tool box talk, should install Sika products (The names of these personnel should be recorded)
- Should the 48 hour notice period not be provided, it is the Contractors responsibility to provide photographs of the applicable area of works i.e. jointing for basement wall section gridline L1 – 4B etc.
- Should the Sika Watertight Site Attendance procedure not be followed, the project may not qualify for the Sika Product Guarantee
- Attendance
 - Sika waterproofing technicians do not generally watch concrete being poured (although on large pours we may visit). Site attendance by Sika is focused on joint installation and generally 48 hours notice is required for viewing by a Sika operative.
 - An attendance log MUST be completed for each site visit and distributed as agreed. This attendance log will cover:
 - General concrete practice
 - Joint installation
 - Detailing
 - Highlight any issues identified
 - Recommended remedy for issues identified
 - Any repairs carried out
- Warranty Issue
 - Once the work has reached practical completion stage, a final attendance will be carried out (this is essential and it is the contractor's responsibility to inform Sika they are ready for this).
 - All Sika watertight concrete must be or have been available for inspection. This will also include checking any repairs carried out by either the Contractor, Sika Limited, or their appointed specialist contractor. Any areas of watertight concrete that were / are not available for inspection may be excluded from any warranty. When all parties are satisfied that a successful job has been achieved, the warranty can be issued to the contractor, to be passed to the client.

670 TRANSPORTING

- General: Avoid contamination, segregation, loss of ingredients, excessive evaporation and loss of workability. Protect from heavy rain.
- Entrained air: Anticipate effects of transport and placing methods in order to achieve specified air content.

680 PLACING

- Records: Maintain for time, date and location of all pours.
- Timing: Place as soon as practicable after mixing and while sufficiently plastic for full compaction.
- Temperature limitations for concrete: 30°C (maximum) and 5°C (minimum), unless otherwise specified. Do not place against frozen or frost covered surfaces.
- Continuity of pours: Place in final position in one continuous operation up to construction joints. Avoid formation of cold joints.
- Discharging concrete: Prevent uneven dispersal, segregation or loss of ingredients or any adverse effect on the formwork or formed finishes
- Thickness of layers: To suit methods of compaction and achieve efficient amalgamation during compaction.
- Poker vibrators: Do not use to make concrete flow horizontally into position, except where necessary to achieve full compaction under void formers and cast-in accessories and at vertical joints.

1.3 - Specifications continues overleaf...

690 COMPACTING

- General: Fully compact concrete to full depth to remove entrapped air. Continue until air bubbles cease to appear on the top surface.
 - Areas for particular attention: Around reinforcement, under void formers, cast-in accessories, into corners of formwork and at joints.
- Consecutive batches of concrete: Amalgamate without damaging adjacent partly hardened concrete.
- Methods of compaction: To suit consistence class and use of concrete.

720 VIBRATORS

- General: Maintain sufficient numbers and types of vibrator to suit pouring rate, consistency and location of concrete.
- External vibrators: Obtain approval for use.

730 PLASTIC SETTLEMENT

- Settlement cracking: Inspect fresh concrete closely and continuously wherever cracking is likely to occur, including the top of deep sections and at significant changes in the depth of concrete sections.
 - Timing: During the first few hours after placing and whilst concrete is still capable of being fluidized by the vibrator.
- Removal of cracks: Revibrate concrete.

810 CURING GENERALLY

- Requirement: Keep surface layers of concrete moist throughout curing period, including perimeters and abutments, by either restricting evaporation or continuously wetting surfaces of concrete.
 - Surfaces covered by formwork: Retain formwork in position and, where necessary to satisfy curing period, cover surfaces immediately after striking.
 - Top surfaces: Cover immediately after placing and compacting. If covering is removed for finishing operations, replace it immediately afterwards.
- Surface temperature: Maintain above 5°C throughout the specified curing period or four days, whichever is longer.
- Records: Maintain details of location and timing of casting of individual batches, removal of formwork and removal of coverings. Keep records on site, available for inspection.

811 COVERINGS FOR CURING

- Sheet coverings: Suitable impervious material.
- Curing compounds: Selection criteria:
 - Curing efficiency: Not less than 90%(ASTMC-309) spray on curing agent (e.g. Sikafloor Proseal).
 - Application to concrete exposed in the finished work: Readily removable without disfiguring the surface.
 - Application to concrete to receive bonded construction/ finish: No impediment to subsequent bonding.
- Interim covering to top surfaces of concrete: Until surfaces are in a suitable state to receive coverings in direct contact, cover with impervious sheeting held clear of the surface and sealed against draughts at perimeters and junctions.

1.3 - Specifications continues overleaf...

812 PREVENTING EARLY AGE THERMAL CRACKING

- Deep lifts or large volume pours: Submit proposals for curing to prevent early age thermal cracking, taking account of:
 - Temperature differentials across sections.
 - Coefficient of thermal expansion of the concrete.
 - Strain capacity of the concrete mix (aggregate dependent).
 - Restraint.

817 CURING CLASS

- Standard: To BS EN 13670

840 PROTECTION

- Prevent damage to concrete, including:
 - Surfaces generally: From rain, indentation and other physical damage.
 - Surfaces to exposed visual concrete: From dirt, staining, rust marks and other disfiguration.
 - Immature concrete: From thermal shock, physical shock, overloading, movement and vibration.
 - In cold weather: From entrapment and freezing expansion of water in pockets, etc.

J40 FLEXIBLE SHEET WATERPROOFING

To be read with Preliminaries / general conditions and the SikaProof A datasheet.

The details contained within this proposal are based on information available at the time of writing. It covers the installation of Sika materials and the preparation work necessary to provide a suitable substrate. Sika Limited cannot be held responsible for unknown site conditions or for the performance of materials within the system other than Sika products or Sika branded products.

A detailed method of work statement and programme of works should be agreed with the contractor before the commencement of the works.

The requirements of all relevant British Standards and Industry Codes of Practice should be complied with at all times.

PERFORMANCE

This specification is for a waterproofing Type A solution in accordance with BS8102:2009 with the design intent of preventing water migration into the below ground structure.

Performance must be as follows:

MANUFACTURER'S GUARANTEE

The membrane manufacturer is to provide a product guarantee that is for the benefit of the end user. This is to be a 15 year product guarantee for single waterproofing systems and a 20 year product guarantee when combined with a Type B or Type C solution in accordance with BS8102:2009 from the same manufacturer. All materials including detailing materials must be from a single source manufacturer.

The membrane manufacturer is to conduct comprehensive and regular inspections during the systems installation. Reports are to be presented to the contractor by the manufacturer.

1.3 - Specifications continues overleaf...

The manufacturer must have Professional Indemnity Insurance for the waterproofing scope of works to the basement and/or foundations where a product guarantee is required.

PRODUCT PERFORMANCE

Sheet waterproofing must have a Environmental Product Declaration (EPD) certificate according to EN 15804 for a sustainable material.

Sheet waterproofing must be able to be supplied, where requested, in a 2m wide roll to reduce the amount of joints present which reduces the risk associated with joints along with reducing labour and programme times.

Sheet waterproofing must provide a crack bridging ability of ≥ 1 mm.

Sheet waterproofing must provide a peel adhesion to concrete of ≤ 60 lbs/in (ASTM D 903). High peel adhesion values should be avoided as high values can affect the crack bridging performance.

Sheet Waterproofing must provide a sealant grid that prevents any lateral water underflow and migration between the waterproofing membrane and the structural concrete in the event of damage.

Sheet Waterproofing resistance to lateral water underflow of membrane to pass up to 7.0 bar (ASTM D 5385mod)

Sheet Waterproofing system must be British Board of Agrément Certificated and CE marked

Sheet Waterproofing must be BBA certified to provide radon protection and able to be used as a gas resistant membrane when used as part of a gas protection system.

Sheet Waterproofing shall be 1.25mm thick, uniform, flexible sheets consisting of 0.8mm thick FPO membrane. Thick FPO membranes have proven long life expectancies and are robust enough for most construction sites.

All detailing materials, waterbars and ancillaries to be provided by a single source manufacturer.

297 WATERPROOFING MEMBRANE

- Substrate: Concrete blinding or Formwork or Rigid thermal Insulation, or Geotextile or Compacted soil/fill with geotextile (only for low requirements) or Plywood. Substrate must be regular and smooth with no gaps or voids greater than 12mm. A sound solid substrate should be created to eliminate movement during the concrete pour. Vertically the membrane can be applied to permanent formwork, rigid insulation and the adjoining structure or as recommended by the manufacturer.
- Manufacturer: Sika Limited, Watchmead, Welwyn Garden City, Hertfordshire, AL7 1BQ.
- Manufacturer must be a member of the Property Care Association
- BIM: www.sikawaterproofing.co.uk/BIM
 - Product reference: SikaProof A-08
 - BBA technical approval for construction and methane protection, Certificate No. 13/5075, 16.12.2013.
- Materials must be CE Marked.
- Number of Layers: 1
 - Thickness/Gauge: 0.8 mm SikaProof A-08
 - Bonding: SikaProof A-08 is a fully and permanently bonded, self-adhesive, composite sheet

1.3 - Specifications continues overleaf...

membrane waterproofing system for reinforced concrete of the main structure. It consists of an embossed polyolefin (FPO) membrane laminated with a sealant grid and a non-woven fleece. The fleece must bond to the poured in-situ structural concrete. Apply membrane with non-woven fleece layer uppermost. SikaProof A-08 to be cold-applied and pre-applied, as it is installed without heat or open-flames, and before the steel reinforcement is fixed and the concrete is poured.

- Joints:

- Laps (minimum): Side and end laps to be a minimum of 90mm. Accurately position sheets to overlap previous sheet along indicated adhesive selvedge, ensure a continuous bond is achieved without creases and roll firmly.
- Sealing: For roll ends, cut edges and for providing continuity of waterproofing at penetrations and detailing employ SikaProof Ex Tape- 150 and SikaProof Tape-150A in accordance with manufacturer's SikaProof instruction manual and standard details. End laps should be staggered to avoid a build up of layers. Roll all laps to ensure good adhesion between sheets in accordance with manufacturer's recommendations.
- Accessories: Waterstops to be from the Sika range of passive or active waterstops for expansion joints and additional protection at construction joints providing single point responsibility (see section E40 clause 310). Ensure surfaces to be covered are clean, smooth and free from standing water, voids, and sharp protrusions.
 - SikaProof® A-08 Edge Tape. 1m wide L- shaped membrane for detailing corners and edges
 - SikaProof® ExTape- 150. 150mm wide tape for sealing external of junctions.
 - SikaProof® Tape -150A. 150mm wide tape for sealing internal junctions.

WORKMANSHIP

310 WORKMANSHIP GENERALLY

- Condition of the substrate:
 - Clean and even textured, free from voids and sharp protrusions. The substrate needs sufficient stability to avoid movement during the construction works. Large gaps and voids (> 12-15 mm) to be closed before Sikaproof A-08 installation.
 - Moisture content: Compatible with damp proofing/ tanking.
 - Air and surface temperature: Do not apply sheet below minimum recommended by the manufacturer.
- Condition of the membrane at completion:
 - Apply materials carefully in accordance with manufacturer's recommendations to provide a completely waterproof, continuous membrane.
 - Protect exposed areas of finished sheeting as recommended by the manufacturer to prevent damage or deterioration during following work.
 - Immediately prior to covering check for damage and repair as necessary.
- Permanent overlaying construction:
 - Cover sheeting with permanent overlying construction within 90 days of membrane application.
 - Concrete to be placed and compacted carefully to avoid damage to membrane.

320 INSPECTION

- Membrane to be inspected by a Sika Limited Waterproofing technician before installation of reinforcement steel, shuttering and final placement of concrete. Repairs to be in accordance with Sika Limited recommendations.

1.3 - Specifications continues overleaf...

- Site attendance by the Sika Limited waterproofing technician is necessary to qualify for the guarantee and is free of charge.
- Copies of site reports of interim and final inspection to be made available if required and previously agreed with applicator.

335 PRIMERS

- Not Required

350 ANGLES IN SELF ADHESIVE DAMP PROOFING/TANKING

- No preformed corners required.
- Formed by SikaProof Membrane.

360 JUNCTIONS WITH PROJECTING DPCS/CAVITY TRAYS

- Adjoining surfaces: Clean and dry.
- DPCS/Cavity trays: Lap and fully bond/seal with sheeting.
 - Continuity with Dpcs or Cavity Trays may be achieved by using products as recommended by the manufacturer.

370 PREFORMED COLLARS FOR PIPES, DUCTS, CABLES ETC

- No preformed collars required.
- Formed by SikaProof Membrane.

380 PROTECTION BOARDS FOR DAMP PROOFING/TANKING

- Sika Drain 850 Geo if required by design.

J40 FLEXIBLE SHEET WATERPROOFING

To be read with Preliminaries / general conditions and the SikaProof P12 datasheet.

The details contained within this proposal are based on information available at the time of writing. It covers the installation of Sika materials and the preparation work necessary to provide a suitable substrate. Sika Limited cannot be held responsible for unknown site conditions or for the performance of materials within the system other than Sika products or Sika branded products.

A detailed method of work statement and programme of works should be agreed with the contractor before the commencement of the works.

The requirements of all relevant British Standards and Industry Codes of Practice should be complied with at all times.

PERFORMANCE

This specification is for a waterproofing Type A solution in accordance with BS8102:2009 with the design intent of preventing water migration into the below ground structure.

Performance must be as follows:

MANUFACTURER'S GUARANTEE

The membrane manufacturer is to provide a product guarantee that is for the benefit of the end user. This is

1.3 - Specifications continues overleaf...

to be a 15 year product guarantee for single waterproofing systems and a 20 year product guarantee when combined with a Type B or Type C solution in accordance with BS8102:2009 from the same manufacturer. All materials including detailing materials must be from a single source manufacturer.

The membrane manufacturer is to conduct comprehensive and regular inspections during the systems installation. Reports are to be presented to the contractor by the manufacturer.

The manufacturer must have Professional Indemnity Insurance for the waterproofing scope of works to the basement and/or foundations where a product guarantee is required.

PRODUCT PERFORMANCE

Sheet waterproofing must have a Environmental Product Declaration (EPD) certificate according to EN 15804 for a sustainable material.

Sheet waterproofing must provide a crack bridging ability of ≥ 1 mm.

Sheet waterproofing must provide adhesion in peel to concrete ≥ 100 N/50mm, in accordance with EN 1372. High peel adhesion values should be avoided as high values can affect the crack bridging performance.

Sheet Waterproofing must provide a sealant grid that prevents any lateral water underflow and migration between the waterproofing membrane and the structural concrete in the event of damage.

Sheet Waterproofing resistance to lateral water underflow of membrane to pass up to 7.0 bar (ASTM D 5385mod)

Sheet Waterproofing system must be British Board of Agrément Certificated and CE marked

Sheet Waterproofing must be BBA certified to provide radon protection and able to be used as a gas resistant membrane when used as part of a gas protection system.

Sheet Waterproofing shall be 1.2mm thick, uniform, flexible sheets consisting of 0.6mm thick FPO membrane. Thick FPO membranes have proven long life expectancies and are robust enough for most construction sites.

All detailing materials, waterbars and ancillaries to be provided by a single source manufacturer.

297 WATERPROOFING MEMBRANE

- Substrate: Concrete or blockwork or masonry. For further more detailed information please refer to the current product datasheet and/or method statement for SikaProof® P.
- Manufacturer: Sika Limited, Watchmead, Welwyn Garden City, Hertfordshire, AL7 1BQ.
- Manufacturer must be a member of the Property Care Association
- Product reference: SikaProof P-12
- Product Declaration - EN 13967 – Flexible sheets for waterproofing (type A&T). Function test for area and standard details, according German & ASTM standards
- Materials must be CE Marked.
- Number of Layers: 1
 - Thickness/Gauge: 1.2 mm SikaProof P-12
 - Bonding: SikaProof P-12 is a state of the art self-adhesive membrane sheets, by peel & stick, with simple and easy fixing and bonding of the membrane onto the prepared surfaces. It consists of an embossed polyolefin (FPO) membrane laminated with a sealant grid and an adhesive bond. SikaProof P-12 to be cold-applied and pre-applied, as it is

1.3 - Specifications continues overleaf...

installed without heat or open-flames.

- Joints & Laps: All overlap joints and laps must be pressed firmly with a pressure roller.
 - Laps : Use the prefabricated overlap at the edge of the sheet
 - The preformed installation marks (black lines on each side) should not be visible, maintain minimum joint overlap 80mm.
 - Transverse / cross joints: Only T-joints - No X- joints, all T-joints must be sealed, minimum overlaps 150mm end of rolls. T-joints must be minimum 300mm apart
 - Detailing joints: Must be sealed and minimum overlap 100mm.
 - General: Use as few joints as possible to minimise risk.
 - Always follow the "umbrella principle", which means that all overlap joints are closed overlapping downwards
 - Always start the sheet membrane installation from the lowest point and work upwards
- Accessories: Waterstops to be from the Sika range of passive or active waterstops for expansion joints and additional protection at construction joints providing single point responsibility (see section E40 clause 310)
- Ensure surfaces to be covered are clean, smooth and free from standing water, voids, and sharp protrusions.
 - SikaProof® ExTape- 150. 150mm wide tape for sealing external of junctions.
 - SikaProof® Tape 50. 50mm wide tape for sealing details.

WORKMANSHIP

310 WORKMANSHIP GENERALLY

- Condition of the substrate:
 - The concrete or other suitable substrate must meet the defined substrate quality. If the substrate does not fulfil the requirements the surface must be pre-treated prior to the application of SikaProof P-12 as per the SikaProof P Method Statement
 - Moisture content: Compatible with damp proofing/ tanking.
 - Air and surface temperature: Do not apply sheet below minimum recommended by the manufacturer.
- Condition of the membrane at completion:
 - Apply materials carefully in accordance with manufacturer's recommendations to provide a completely waterproof, continuous membrane.
 - Protect exposed areas of finished sheeting as recommended by the manufacturer to prevent damage or deterioration during following work.
 - Immediately prior to covering check for damage and repair as necessary.
 - SikaProof® P-12 membrane sheets must to be protected after installation before the backfilling, to prevent mechanical damage.
- Permanent overlaying construction:
 - Cover sheeting with permanent overlying construction within 90 days of membrane application.

320 INSPECTION

- Membrane to be inspected after application and prior to back filling by a Sika Limited Waterproofing technician. Repairs to be in accordance with Sika Limited recommendations.
- Site attendance by the Sika Limited waterproofing technician is necessary to qualify for the guarantee and is free of charge.
- Copies of site reports of interim and final inspection to be made available by Sika Limited if required

1.3 - Specifications continues overleaf...

and previously agreed with applicator.

335 PRIMERS

- SikaProof Primer 0-1

350 ANGLES IN SELF ADHESIVE DAMP PROOFING/TANKING

- No preformed corners required.
- Formed by SikaProof Membrane.

360 JUNCTIONS WITH PROJECTING DPCS/CAVITY TRAYS

- Adjoining surfaces: Clean and dry.
- DPCS/Cavity trays: Lap and fully bond/seal with sheeting.
 - Continuity with Dpcs or Cavity Trays may be achieved by using products as recommended by the manufacturer.

370 PREFORMED COLLARS FOR PIPES, DUCTS, CABLES ETC

- No preformed collars required.
- Formed by SikaProof Membrane.

380 PROTECTION BOARDS FOR DAMP PROOFING/TANKING

- Sika Drain 850 Geo.

R16 FLEXIBLE SHEET DAMP PROOFING

To be read with Preliminaries / general conditions and the Sika Drain 850 Geo datasheet.

The details contained within this proposal are based on information available at the time of writing. Sika Limited cannot be held responsible for unknown site conditions or for the performance of materials within the system other than Sika products or Sika branded products.

A detailed method of work statement and programme of works should be agreed with the contractor before the commencement of the works.

The requirements of all relevant British Standards and Industry Codes of Practice should be complied with at all times.

380 GROUND WATER PRESSURE RELIEF

Sika® Drain-850 Geo is a heavy duty drainage and protection sheet produced from high density polyethylene (HDPE) with dimples 10 mm high and a filtration layer of geotextile (PP) bonded on the top.

Sika® Drain-850 Geo provides a protection and drainage sheet for preformed sheet membrane waterproofing systems, liquid applied membranes and with the Sika basements and podiums.

- Manufacturer: Sika Limited, Watchmead, Welwyn Garden City, Hertfordshire, AL7 1BQ
- www.sikawaterproofing.co.uk
- + 44 (0)1707 394444
- Product reference: SikaDrain 850 Geo
- Number of Layers: 1
- Thickness: 10 mm (+/- 1.0) mm

1.3 - Specifications continues overleaf...

- Unit Weight: 975g/m²
- Drainage Capacity Vertical: Maximum 3.5 l/(m*s)
- Drainage Capacity Horizontal: Maximum 0.6 l/(m*s)
- Compression Resistance: 400 (+/- 80) kPa (short term)

E40 DESIGNED JOINTS IN IN-SITU CONCRETE

To be read with Preliminaries / general conditions and the SikaSwell A datasheet.

The details contained within this proposal are based on information available at the time of writing. It covers the installation of Sika materials and the preparation work necessary to provide a suitable substrate. Sika Limited cannot be held responsible for unknown site conditions or for the performance of materials within the system other than Sika products or Sika branded products.

A detailed method of work statement and programme of works should be agreed with the contractor before the commencement of the works.

The requirements of all relevant British Standards and Industry Codes of Practice should be complied with at all times.

120 CONSTRUCTION JOINTS GENERALLY

- Accuracy: Position and form joints accurately, straight, well- aligned and truly vertical or horizontal or parallel with setting out lines of the building.
- Modifications to joint design or location: Submit proposals.
- Placing concrete to form movement joints:
 - Maintain effectiveness of joints. Prevent concrete entering joints or penetrating or impregnating compressible joint fillers.

230 PREPARATION OF CONSTRUCTION JOINTS

- Roughening of joint surfaces:
 - Remove surface laitance and expose aggregate finish with a surface retarder.
 - Other methods: Submit proposals.
- Condition of joint surfaces immediately before placing fresh concrete: Clean and free from ponded or running water.

320 HYDROPHILIC WATERSTOPS

- Manufacturer: Sika Limited
 - Product Reference: SikaSwell Profile 2005 and/or SikaSwell Profile 2010.
- Location: Construction Joints
- Method of fixing: Fixing methods:
 - SikaSwell®- A Profiles can be fixed with SikaSwell® S-2.
 - SikaSwell® S-2 must be extruded in sufficient quantity to level the roughness of the substrate.
 - Apply SikaSwell® S-2 in a narrow bed (size of triangular section ~ 10 mm) to the substrate. The profiles must be placed within 30 minutes and pressed well into the still fresh SikaSwell® S-2 sealant until small quantities of SikaSwell® S-2 ooze out from both side of the profiles.
 - Allow SikaSwell® S-2 to harden for 2 - 3 hours before placing concrete.
- General:
 - It is important that a full and continuous contact between the SikaSwell®- Profiles and the substrate is achieved.

1.3 - Specifications continues overleaf...

- Place SikaSwell®- Profiles in the centre of the concrete section.
- Minimum cover to profiles on both sides must be 75 mm (reinforced concrete) or 150 mm (non-reinforced concrete).
- Connections and corners must be butt jointed and fixed with SikaSwell® S-2.
- During concreting, compact well around SikaSwell®- Profiles to provide a dense concrete without honeycombs or voids.
- Condition of concrete surface at time of fixing: Clean and free from ponded or running water.
- Protection: Prevent wetting of exposed sections of waterstop. Swelling of the hydrophilic waterstop before concreting, that affected areas would need to be removed and replaced with new material.

E40 DESIGNED JOINTS IN IN-SITU CONCRETE

To be read with Preliminaries / general conditions and the Sika Metalsheet-FBV Joint Waterstop datasheet.

The details contained within this proposal are based on information available at the time of writing. It covers the installation of materials and the preparation work necessary to provide a suitable substrate. The manufacturer cannot be held responsible for unknown site conditions or for the performance of materials within the system other than the

Manufacturer's products or the manufacturers branded products.

A detailed method of work statement and programme of works should be agreed with the contractor before the commencement of the works.

The requirements of all relevant British Standards and Industry Codes of Practice should be complied with at all times.

120 CONSTRUCTION JOINTS GENERALLY

- Accuracy: Position and form joints accurately, straight, well- aligned and truly vertical or horizontal or parallel with setting out lines of the building.
- Modifications to joint design or location: Submit proposals.
- Placing concrete to form movement joints:
 - Maintain effectiveness of joints. Prevent concrete entering joints or penetrating or impregnating compressible joint fillers.

230 PREPARATION OF CONSTRUCTION JOINTS

- Roughening of joint surfaces:
 - Remove surface laitance and expose aggregate finish with a surface retarder.
 - Other methods: Submit proposals.
- Condition of joint surfaces immediately before placing fresh concrete: Clean and free from ponded or running water.

310 FLEXIBLE WATERSTOPS

- Manufacturer: Sika Ltd, Watchmead, Welwyn Garden City, AL7 1BQ
 - Product Reference: Sika Metalsheet-FBV Joint Waterstop
- Sika Metalsheet-FBV Joint Waterstop is fixed by brackets to the reinforcement. The coated side of

1.3 - Specifications continues overleaf...

the waterstop is installed to the water facing direction.

- Corners are formed by bending.
- The lower half of the plastic strip is removed prior to the fixing of the metal waterstop. (Alternatively this can also be done after fixing).
- Sika Metalsheet-FBV Joint Waterstop is placed centrally in the construction joint – the coated side facing in the direction of the water pressure i.e. basement use, the metal waterbar would be placed with the coated strip facing the external side of the basement. The minimum distance to reinforcing bars shall be 30 mm.
- Sika Metalsheet-FBV Joint Waterstop is fixed to the reinforcement with the Fixing clamp and tying wire at 500 mm spacing's. In corner areas, the distance of the clamps shall be maximum 200 mm to the corner.
- The clamp is installed with the shorter end on the coated side.
- The joints are to be overlapped by 100 mm. The protection film removed, the ends tightly compressed and safeguarded with a Fixing clamp or a Jointing clip.

1.4 - SAMPLE GUARANTEE

Guarantee Application and Issue

Once the work has reached practical completion stage, a Final Assessment must be carried out with no exceptions (contractor's responsibility to inform Sika they are ready for the assessment). All Sika waterproofing materials must be or have been available for visual check, this includes any repairs carried out by either the Contractor, Sika Limited, or their appointed specialist contractor. Any areas of waterproofing that were / are not available for assessment may be excluded from any guarantee. When all parties are satisfied that a successful job has been achieved, the **Sika Application for Waterproofing Guarantee form must be completed** by the installing contractor and returned to Sika **within 12 months of final assessment**. The guarantee can then be issued to the contractor for forwarding to the client.

It is the responsibility of the contractor named in this specification to ensure that the following stages are completed in order for Sika Ltd to be able to issue the guarantee.

- Sika tool-box talk for installing operatives prior to commencement
- Interim site visit(s)
- Actions and non-conformities identified in the Site Attendance Log have been completed to Sika's satisfaction
- Final Assessment prior to commencing internal works, i.e. plastering or covering over the concrete. The areas must be clear, dry and accessible for the final assessment
- Complete and return the Sika Application for Waterproofing Guarantee form (see link in Appendix)

SIKA DUAL SYSTEM GUARANTEE FOR WATERTIGHT STRUCTURAL CONCRETE AND SIKAPROOF (20 Years)

SPECIMEN

Guarantee No:

The Works: (Give address and short description of works in which the Sika product is to be used)

The Owner: The Owner of the structure of which the Works form part

Sika-Products: Our below ground waterproofing products as specified and used by you in the Works

Installing Contractor: (name of contractor who installed the Sika waterproofing materials guaranteed)

Waterproofing Area: (area/volume of Sika waterproofing material guaranteed)

Start date:

Guarantee period: 20 years from the Start date

1. Contractual Background

- Sika Limited, Watchmead, Welwyn Garden City, Herts AL7 1BQ is the manufacturer and supplier of the Dual System for production of watertight structural concrete used in conjunction with a SikaProof fully bonded membrane.
- This Guarantee is granted for the benefit of Owner and may be transferred to subsequent Owners of the structure.

1.4 - Sample Guarantee continues overleaf...

- Sika Watertight Concrete System can comprise of: Sika Watertight Concrete Powder, or WT200P, or Sika-1+ (in conjunction with Sika high range water reducing admixtures). Each of which when used is added to the concrete mix.

2. Design

This guarantee will only apply if:

- the Sika Structural Watertight Concrete element is used in structural concrete for Type B construction as described in BS 8102:2009, the structural concrete element is to be designed in accordance with the flexural and thermal crack limitations of 0.3 mm as stated in BS EN 1992 Eurocode 2, or the limitations of 0.2 mm as stated in BS 8007, when carried out in accordance with the BBA Certificate (Certificate no 08/4606) and the current technical data sheets; and
- the SikaProof membrane is installed and detailed correctly in accordance with the Standard Details and Application Guide issued by Sika Limited and any specific project advice given by Sika Technical personnel and in accordance with the BBA Certificate (Certificate 13/5075).
- the SikaProof® membrane is installed by a contractor approved by Sika Limited, having received the appropriate training.

3. Sika Limited agree to the remedies herein set out if there is visible water permeation through the Dual System in which the Sika Structural Watertight Concrete is properly compacted during the period of twenty (20) years from the date of effective completion of the Dual System concrete structure, save as expressly excluded and in any event subject strictly to the conditions as laid out herein.

4. Exclusions

This guarantee excludes the penetration of water...

- through cracks caused by design failure or overloading of the structure; or
- through expansion joints; or
- at any point where the designed thickness of the concrete has been reduced; or
- through honeycombing and/or voids made as a result of poor compaction of the Sika Structural Watertight Concrete element in the Dual System concrete or leaking formwork; or
- through concrete that has been disturbed or tampered with; or
- through concrete that does not conform to current British Standards; or
- through cracks in podium or suspended slabs.

This guarantee excludes liability for damage to, or failure of the Sika Structural Watertight Concrete System waterproofing caused by:-

- incorrect application; or
- poor workmanship including but not limited to the failure of the Contractor to ensure that the total cementitious content in the Sika Structural Watertight Concrete System concrete is no less than 350kgs per cubic metre; or
- fire, explosion, vibration, structural movement outside the design requirements of BS EN 1992 Eurocode 2; or
- lightning, thunderbolt, earthquake, riot, civil commotion, strikes or labour disturbances.

This Guarantee excludes any damage arising by reason of the failure of any Contractor engaged with the Works or their suppliers, to comply with the main specifications tendered on, and the detailed specifications, recommended joint and projection details, terms and conditions as set out by Sika Limited for the use of the Sika Structural Watertight Concrete System.

1.4 - Sample Guarantee continues overleaf...

Nothing in this guarantee shall have effect to exclude or limit any liability the exclusion or limitation of which is forbidden by law.

Save as expressly stated herein, Sika shall not be liable in connection with the Sika-Products for the Building, for any loss of income, loss of actual or anticipated profits, loss of business, loss of contracts, loss of goodwill or reputation, loss of business, loss of anticipated savings or indirect or consequential loss or damage of any kind, in each case howsoever arising, whether such loss or damage was foreseeable or in the contemplation of the parties and whether arising in or caused by breach of contract, tort (including negligence), breach of statutory duty or otherwise.

5. Conditions

- Sika Limited shall be notified in writing of any non-performance of the Dual System and the area of non-performance within 14 days after such non-performance shall have come to the knowledge of the Client or his representative having supervision of the Dual System concrete works.

6. Remedies

- Sika Limited's liability for any non-performance of the Dual System under this guarantee shall not in any event exceed the sale value of the Dual System products supplied by Sika Limited, used in constructing the particular structure and paid for by its direct customer, and is strictly limited only to the direct cost of repairs to, or rectification of the Dual System concrete structure through which visible water is permeating.
- Remedial work, if necessary, will be carried out by and at the expense of Sika Limited, in a manner as may be directed by Sika or our nominee as soon as practicable after advice of any non-performance of the Dual System has been received. The performance of such repairs will be considered by Sika to be included under this Guarantee.

7. This Guarantee may be assigned. Each assignment becomes effective on the date of notice being given to Sika, stating name and address of the assignee.

8. This Guarantee is governed by English law and the parties submit to the exclusive jurisdiction of the English courts to resolve any disputes arising out of or in connection with this Guarantee.

9. The parties to this Guarantee do not intend that any term of this Guarantee may be relied upon or shall be enforceable by virtue of the Contracts (Rights of Third Parties) Act 1999 or otherwise by any person who is not a party to this Guarantee or expressly stated to enjoy the benefit of it.

Date:

Signed for Sika Limited

Product Manager / Area Specification Manager

2 APPENDICES

2.1 DISCLAIMER

The information, and, in particular, the recommendations relating to the application and end-use of Sika products, are given in good faith based on Sika's current knowledge and experience of the products when properly stored, handled and applied under normal conditions in accordance with Sika's recommendations. In practice, the differences in materials, substrates and actual site conditions are such that no warranty in respect of merchantability or of fitness for a particular purpose, nor any liability arising out of any legal relationship whatsoever, can be inferred either from this information, or from any written recommendations, or from any other advice offered. The user of the product must test the products suitability for the intended application and purpose. Sika reserves the right to change the properties of its products. The proprietary rights of third parties must be observed. All orders are accepted subject to our current terms of sale and delivery. Users must always refer to the most recent issue of the local Product Data Sheet for the product concerned, copies of which will be supplied on request.

2.2 DRAWINGS

A	A01 SIKAPROOF A MAIN SECTION	VIEW
B	A02 SIKAPROOF A GROUND LEVEL TERMINATION	VIEW
C	A03 SIKAPROOF TIEBAR SEAL - X-PLUG	VIEW
D	A04 SIKAPROOF A PIPE PENETRATION THROUGH RC WALL	VIEW
E	A07 SIKAPROOF A LIFT PIT (OPTION 1)	VIEW
F	A08 SIKAPROOF A LIFT PIT (OPTION 2)	VIEW
G	A09 SIKAPROOF A PIPE THROUGH RC SLAB	VIEW

2.3 PROJECT RELATED DOCUMENTATION

Plot 2 - 3 Basement

PDS Sika Watertight Concrete Powder	VIEW
PDS SikaSwell S-2	VIEW

2.3 Project Related Documentation continues overleaf...

PDS SikaSwell A Profiles	VIEW
PDS SikaProof A Edge	VIEW
PDS SikaProof Ex-Tape 150	VIEW
PDS SikaProof Patch 200 B	VIEW
PDS SikaProof Primer-01	VIEW
PDS SikaProof Tape 150 A	VIEW
PDS SikaProof P-12	VIEW
PDS Sika Metalsheet-FBV joint waterstop	VIEW
BBA Sika Watertight Concrete Powder	VIEW
BBA SikaProof A	VIEW
BBA SikaSwell A2010	VIEW
EPD SikaProof A	VIEW
EPD SikaProof P	VIEW
PDS Sika Drain-850 Geo	VIEW
BBA SikaProof P	VIEW
PDS SikaProof A-08	VIEW
Guarantee Application Form	VIEW

SIKAPROOF A MAIN SECTION

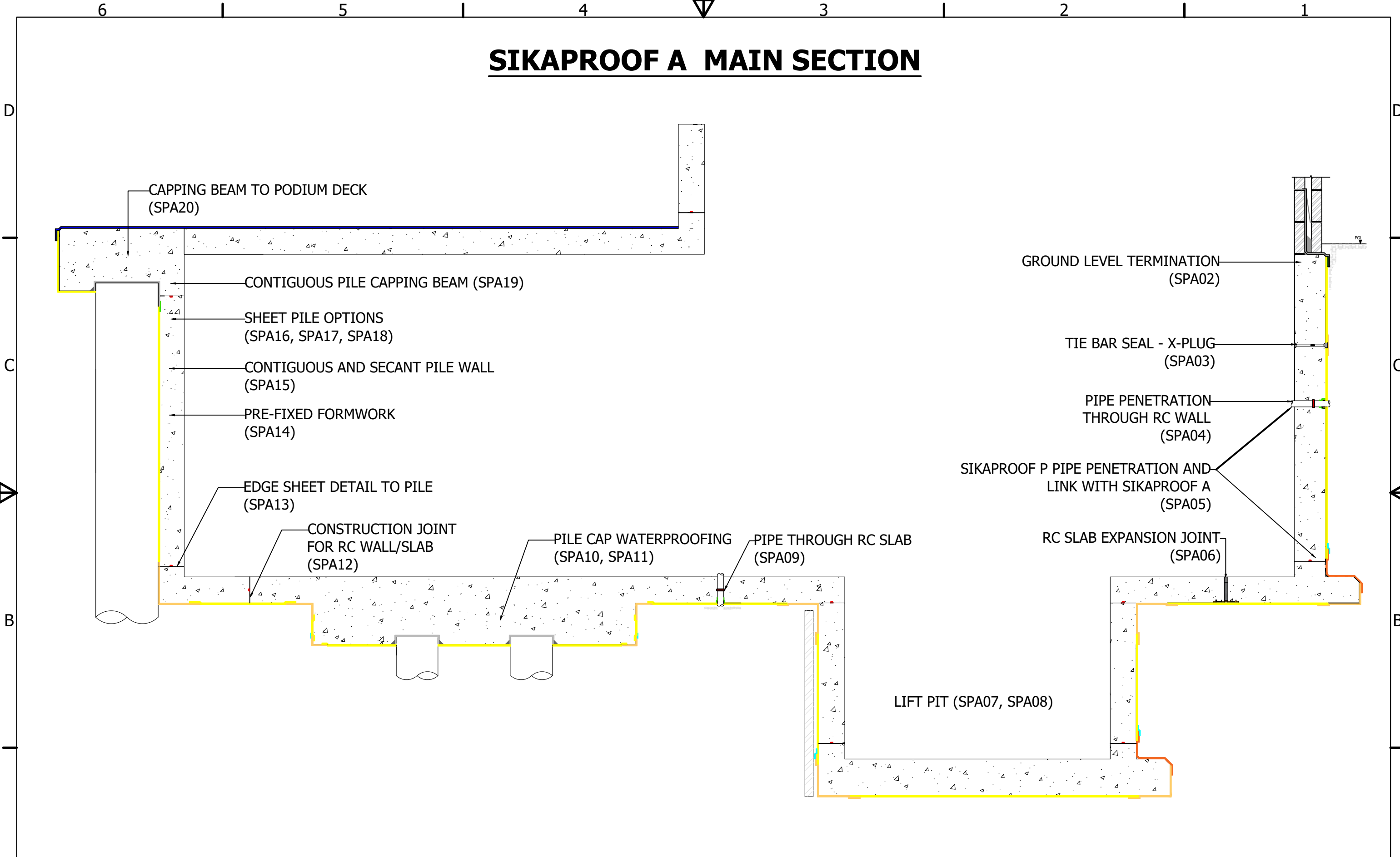

The information contained herein and any other advice are given in good faith based on Sika's current knowledge and experience of the products when properly stored, handled and applied under normal conditions in accordance with Sika's recommendations. The information only applies to the application(s) and product(s) expressly referred to herein and is based on laboratory tests which do not replace practical tests. In case of changes in the parameters of the application, such as changes in substrates etc., or in case of a different application, consult Sika's Technical Service prior to using Sika products. The information contained herein does not relieve the user of the products from testing them for the intended application and purpose. All orders are accepted subject to our current terms of sale and delivery. Users must always refer to the most recent issue of the local Product Data Sheet for the product concerned, copies of which will be supplied on request.

**ALL DIMENSIONS ARE IN MM
UNLESS STATED
DO NOT SCALE FROM
DRAWING**

THIS DRAWING IS THE
CONFIDENTIAL PROPERTY OF SIKA
LIMITED AND MUST NOT BE
REPRODUCED EITHER WHOLLY OR
PARTLY. ALL RIGHTS IN RESPECT OF
PATENTS, DESIGN AND COPYRIGHTS
ARE RESERVED. SIKALTD.
WWW.SIKA.CO.UK



Drawn by <i>A. O'Ferrall</i>	Checked by <i>D. Cliff</i>	Approved by <i>A. Burman</i>	Date 24/11/17
Description SIKAPROOF A MAIN SECTION			
Drawing No. SPA01		Issue A	Sheet 1 / 1

SIKAPROOF GROUND LEVEL TERMINATION

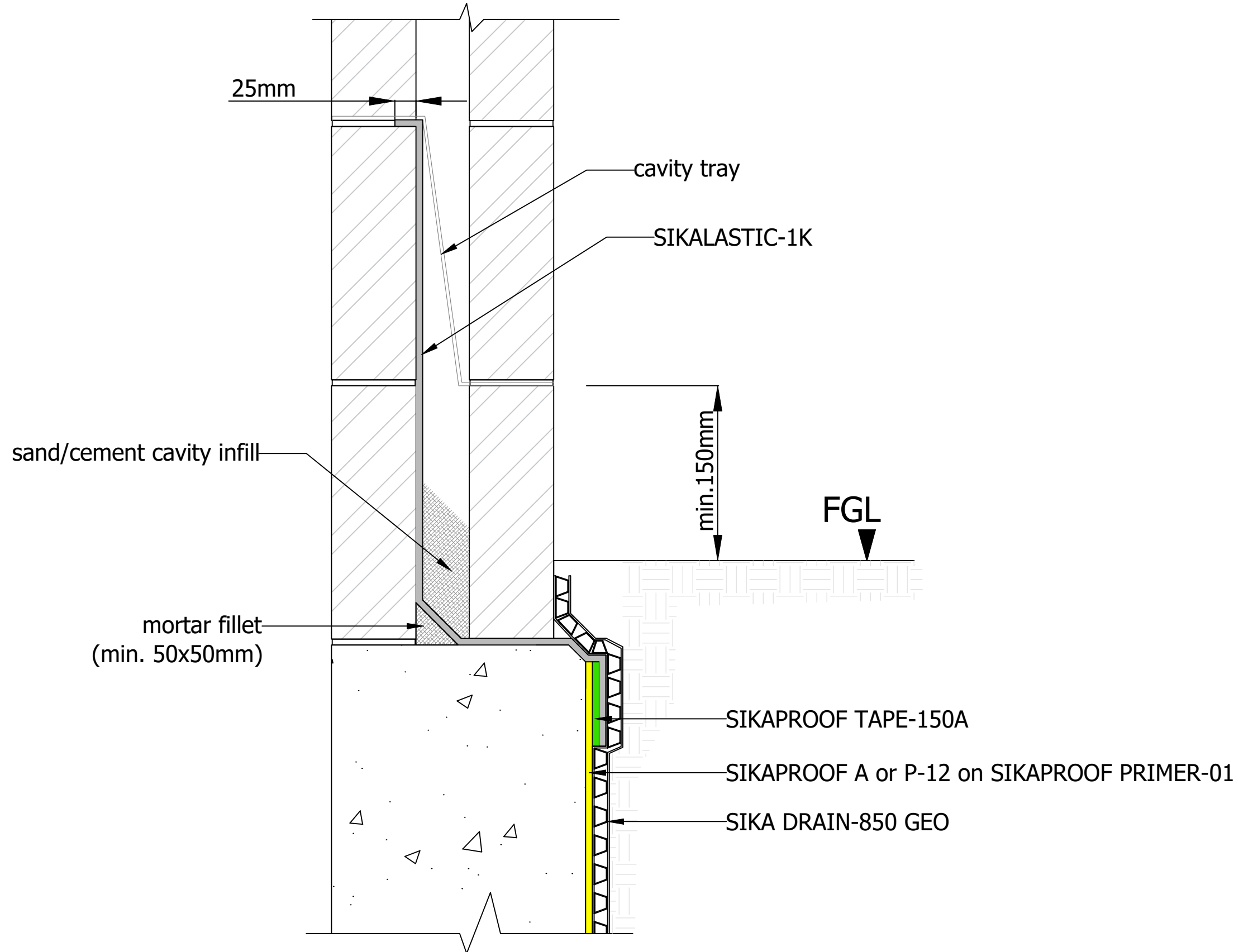

DRAWINGS MUST ALWAYS BE REVIEWED BY A DESIGN SPECIALIST AND IF NECESSARY MODIFIED TO ENSURE SUITABILITY FOR THE SPECIFIC APPLICATION.

The information contained herein and any other advice are given in good faith based on Sika's current knowledge and experience of the products when properly stored, handled and applied under normal conditions in accordance with Sika's recommendations. The information only applies to the application(s) and product(s) expressly referred to herein and is based on laboratory tests which do not replace practical tests. In case of changes in the parameters of the application, such as changes in substrates etc., or in case of a different application, consult Sika's Technical Service prior to using Sika products. The information contained herein does not relieve the user of the products from testing them for the intended application and purpose. All orders are accepted subject to our current terms of sale and delivery. Users must always refer to the most recent issue of the local Product Data Sheet for the product concerned, copies of which will be supplied on request.

ALL DIMENSIONS ARE IN MM
UNLESS STATED
DO NOT SCALE FROM
DRAWING

THIS DRAWING IS THE
CONFIDENTIAL PROPERTY OF SIKA
LIMITED AND MUST NOT BE
REPRODUCED EITHER WHOLLY OR
PARTLY. ALL RIGHTS IN RESPECT OF
PATENTS, DESIGN AND COPYRIGHTS
ARE RESERVED. SIKA LTD.
WWW.SIKA.CO.UK



Drawn by <i>A. O' ferrall</i>	Checked by <i>D. Cliff</i>	Approved by <i>A. Burman</i>	Date 22/11/18
Description SIKAPROOF GROUND LEVEL TERMINATION			
Drawing No. SPA02		Issue D	Sheet 1 / 1

SIKAPROOF TIE BAR SEAL - X-PLUG

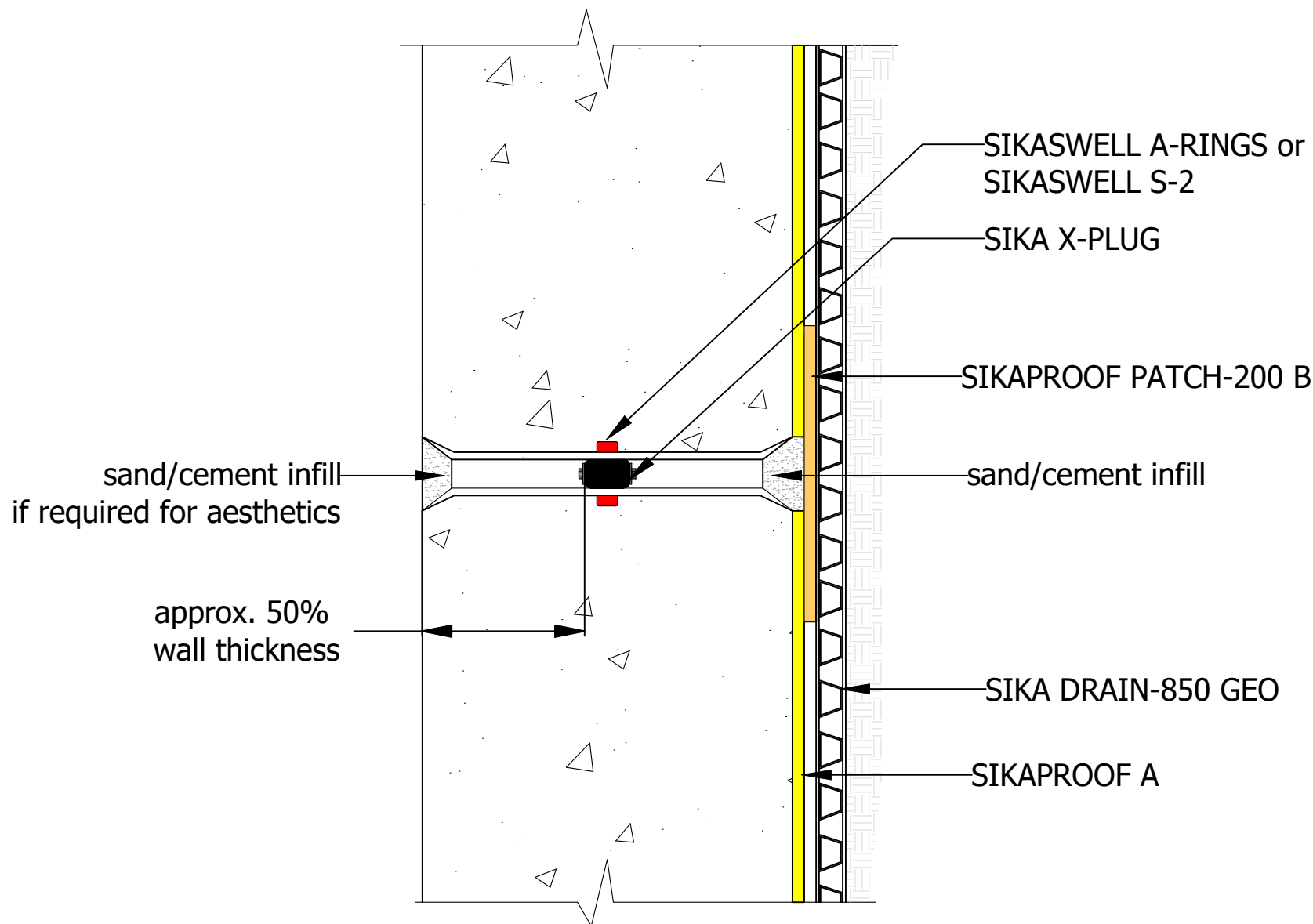

**SIKAPROOF A
(With Sleeve)**

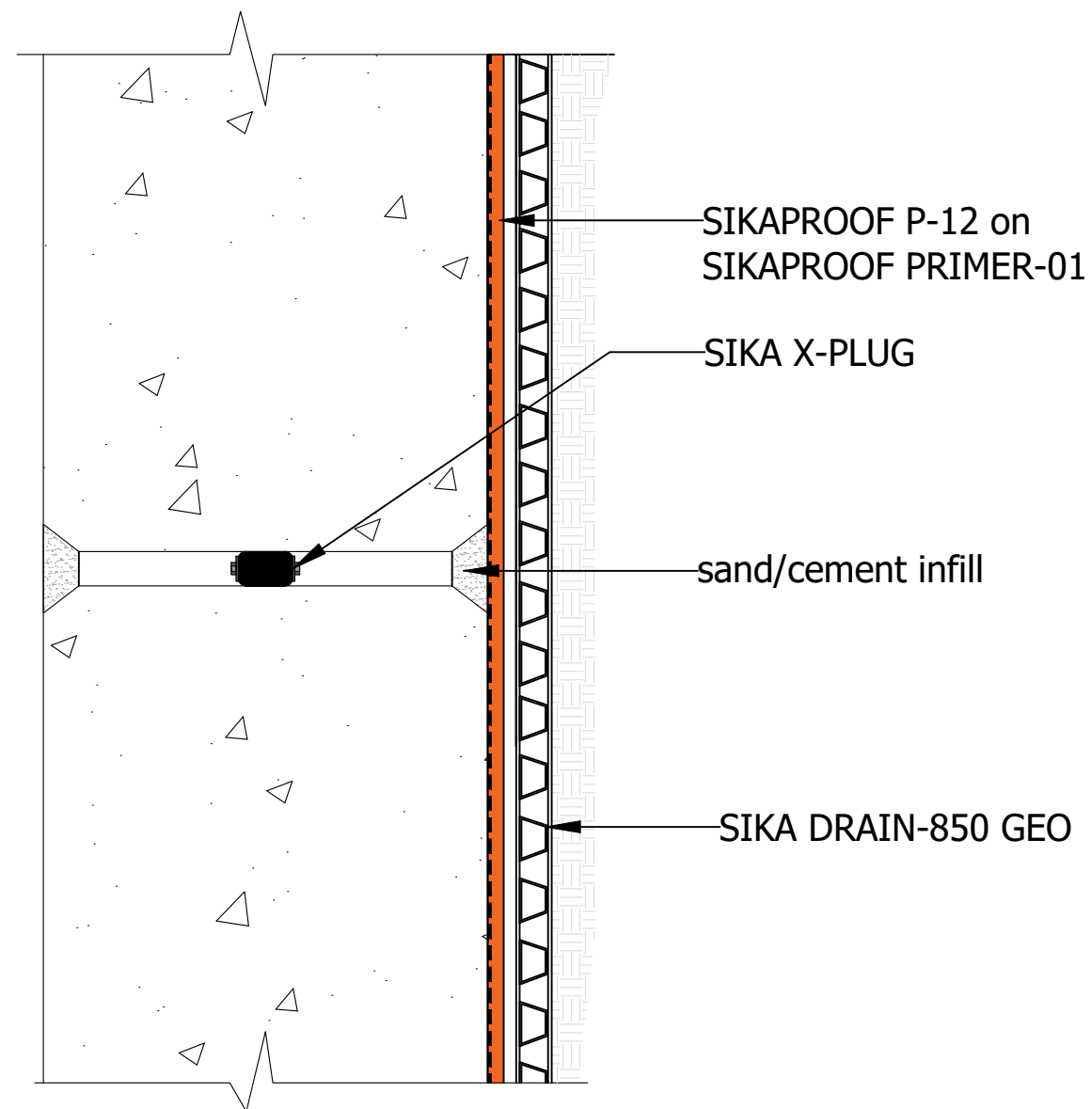

**SIKAPROOF P-12
(Without Sleeve)**

A DRAWINGS MUST ALWAYS BE REVIEWED BY A DESIGN SPECIALIST AND IF NECESSARY MODIFIED TO ENSURE SUITABILITY FOR THE SPECIFIC APPLICATION.

The information contained herein and any other advice are given in good faith based on Sika's current knowledge and experience of the products when properly stored, handled and applied under normal conditions in accordance with Sika's recommendations. The information only applies to the application(s) and product(s) expressly referred to herein and is based on laboratory tests which do not replace practical tests. In case of changes in the parameters of the application, such as changes in substrates etc., or in case of a different application, consult Sika's Technical Service prior to using Sika products. The information contained herein does not relieve the user of the products from testing them for the intended application and purpose. All orders are accepted subject to our current terms of sale and delivery. Users must always refer to the most recent issue of the local Product Data Sheet for the product concerned, copies of which will be supplied on request.

ALL DIMENSIONS ARE IN MM
UNLESS STATED
DO NOT SCALE FROM
DRAWING

THIS DRAWING IS THE
CONFIDENTIAL PROPERTY OF SIKALIMITED AND MUST NOT BE
REPRODUCED EITHER WHOLLY OR
PARTLY. ALL RIGHTS IN RESPECT OF
PATENTS, DESIGN AND COPYRIGHTS
ARE RESERVED. SIKALTD.
WWW.SIKA.CO.UK



Drawn by <i>A. O'Ferrall</i>	Checked by <i>D. Cliff</i>	Approved by <i>A. Burman</i>	Date 22/11/18
Description SIKAPROOF TIEBAR SEAL - X-PLUG			
Drawing No. SPA03		Issue C	Sheet 1 / 1

6 | 5 | 4 | 3 | 2 | 1

6 | 5 | 4 | 3 | 2 | 1

SIKAPROOF A PIPE PENETRATION THROUGH RC WALL

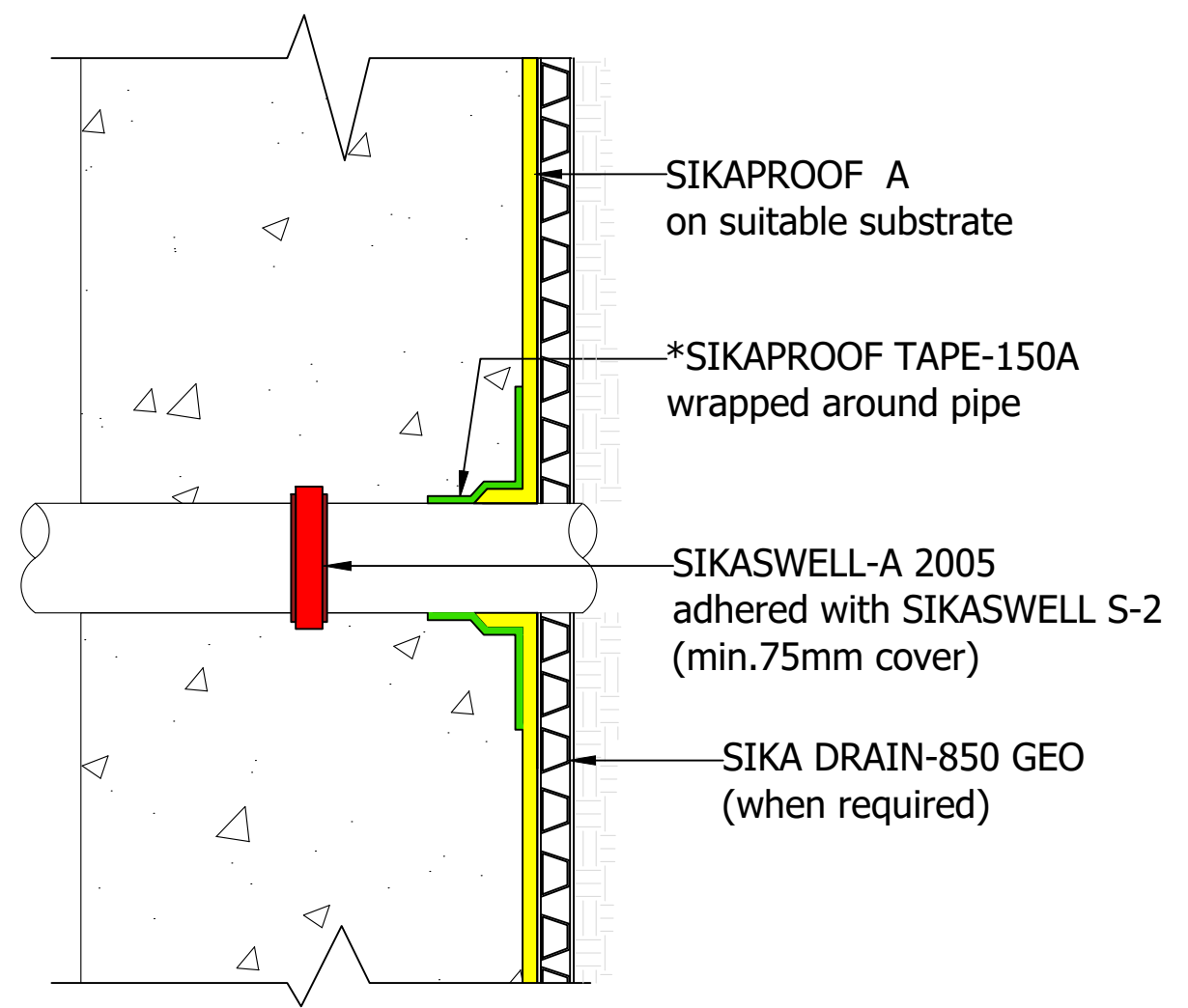
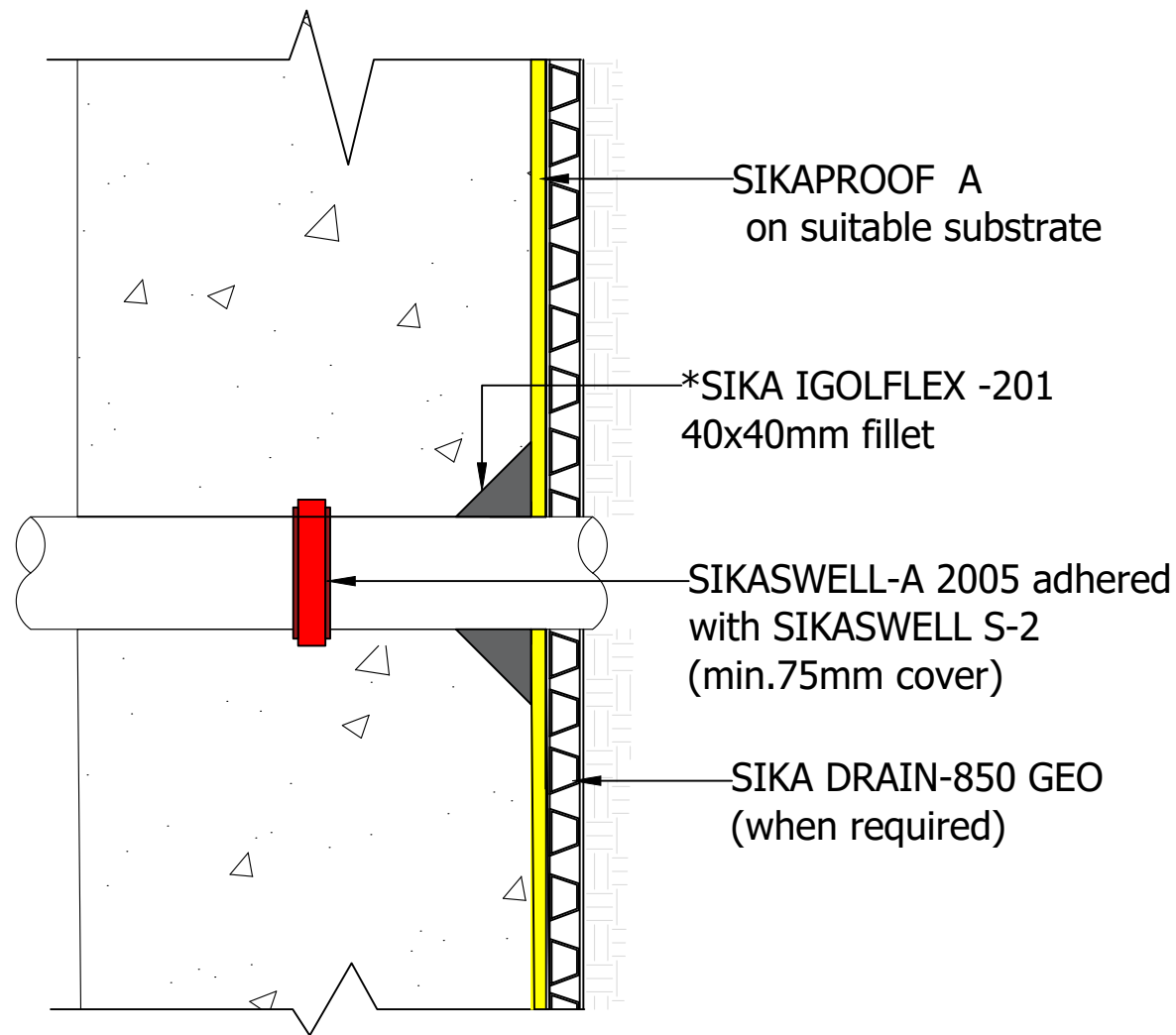

*ALTERNATIVE SEALING METHOD

The information contained herein and any other advice are given in good faith based on Sika's current knowledge and experience of the products when properly stored, handled and applied under normal conditions in accordance with Sika's recommendations. The information only applies to the application(s) and product(s) expressly referred to herein and is based on laboratory tests which do not replace practical tests. In case of changes in the parameters of the application, such as changes in substrates etc., or in case of a different application, consult Sika's Technical Service prior to using Sika products. The information contained herein does not relieve the user of the products from testing them for the intended application and purpose. All orders are accepted subject to our current terms of sale and delivery. Users must always refer to the most recent issue of the local Product Data Sheet for the product concerned, copies of which will be supplied on request.

ALL DIMENSIONS ARE IN MM
UNLESS STATED
DO NOT SCALE FROM
DRAWING

THIS DRAWING IS THE
CONFIDENTIAL PROPERTY OF SIKALIMITED AND MUST NOT BE
REPRODUCED EITHER WHOLLY OR
PARTLY. ALL RIGHTS IN RESPECT OF
PATENTS, DESIGN AND COPYRIGHTS
ARE RESERVED. SIKALTD.
WWW.SIKA.CO.UK



Drawn by <i>A. O'Ferrall</i>	Checked by <i>D. Cliff</i>	Approved by <i>A. Burman</i>	Date 24/11/17
Description <u>SIKAPROOF A PIPE PENETRATION THROUGH RC WALL</u>			
Drawing No. SPA04		Issue A	Sheet 1 / 1

SIKAPROOF A LIFT PIT (OPTION 1)

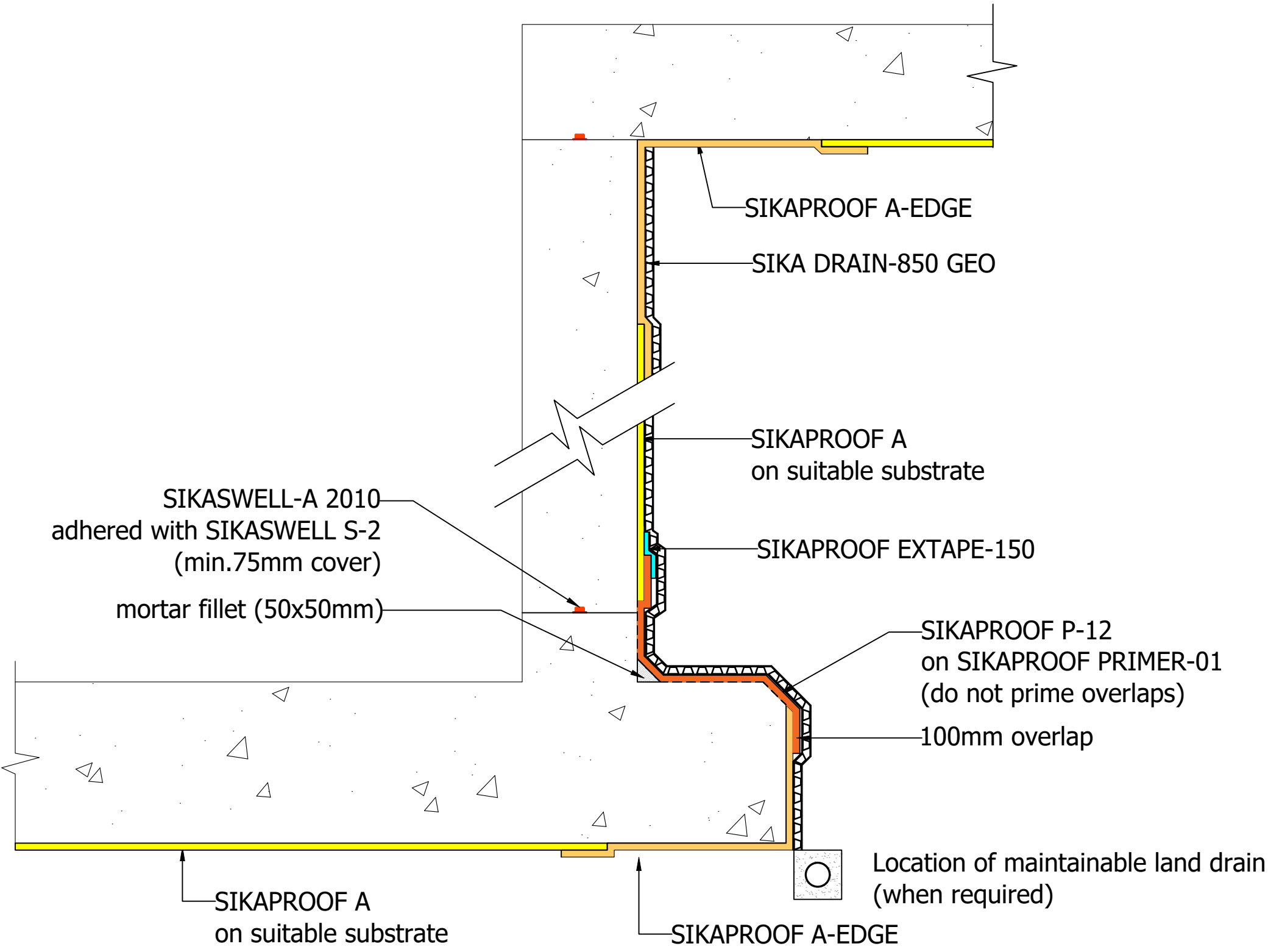

A DRAWINGS MUST ALWAYS BE REVIEWED BY A DESIGN SPECIALIST AND IF NECESSARY MODIFIED TO ENSURE SUITABILITY FOR THE SPECIFIC APPLICATION.

The information contained herein and any other advice are given in good faith based on Sika's current knowledge and experience of the products when properly stored, handled and applied under normal conditions in accordance with Sika's recommendations. The information only applies to the application(s) and product(s) expressly referred to herein and is based on laboratory tests which do not replace practical tests. In case of changes in the parameters of the application, such as changes in substrates etc., or in case of a different application, consult Sika's Technical Service prior to using Sika products. The information contained herein does not relieve the user of the products from testing them for the intended application and purpose. All orders are accepted subject to our current terms of sale and delivery. Users must always refer to the most recent issue of the local Product Data Sheet for the product concerned, copies of which will be supplied on request.

**ALL DIMENSIONS ARE IN MM
UNLESS STATED
DO NOT SCALE FROM
DRAWING**

THIS DRAWING IS THE
CONFIDENTIAL PROPERTY OF SIKA
LIMITED AND MUST NOT BE
REPRODUCED EITHER WHOLLY OR
PARTLY. ALL RIGHTS IN RESPECT OF
PATENTS, DESIGN AND COPYRIGHTS
ARE RESERVED. SIKA LTD.
WWW.SIKA.CO.UK



Drawn by <i>A. O'Ferrall</i>	Checked by <i>D. Cluff</i>	Approved by <i>A. Burman</i>	Date 11/04/18
SIKAPROOF A LIFT PIT (OPTION 1)			
Drawing No. SPA07		Issue B	Sheet 1 / 1

SIKAPROOF A LIFT PIT (OPTION 2)

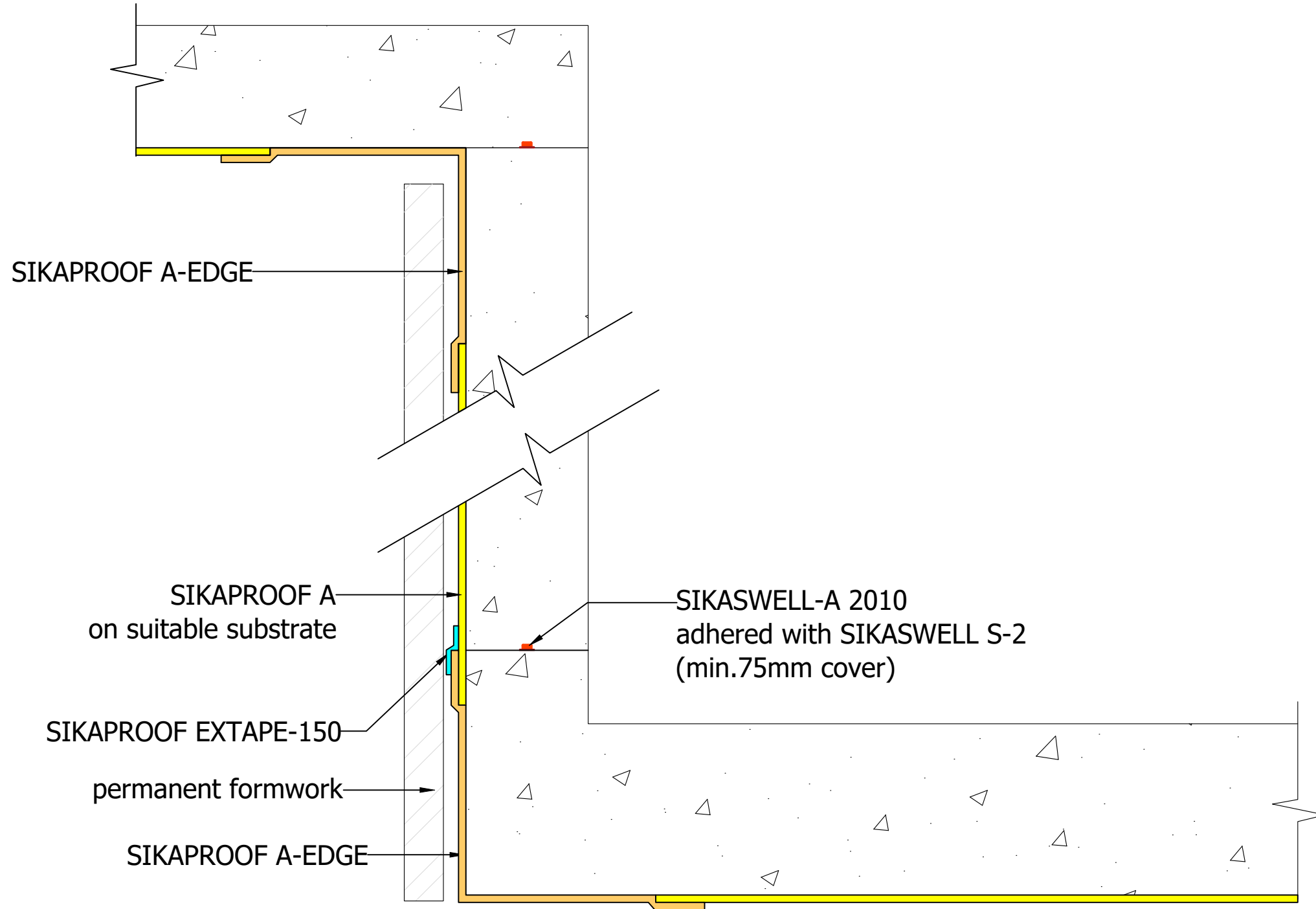

The information contained herein and any other advice are given in good faith based on Sika's current knowledge and experience of the products when properly stored, handled and applied under normal conditions in accordance with Sika's recommendations. The information only applies to the application(s) and product(s) expressly referred to herein and is based on laboratory tests which do not replace practical tests. In case of changes in the parameters of the application, such as changes in substrates etc., or in case of a different application, consult Sika's Technical Service prior to using Sika products. The information contained herein does not relieve the user of the products from testing them for the intended application and purpose. All orders are accepted subject to our current terms of sale and delivery. Users must always refer to the most recent issue of the local Product Data Sheet for the product concerned, copies of which will be supplied on request.

**ALL DIMENSIONS ARE IN MM
UNLESS STATED
DO NOT SCALE FROM
DRAWING**

THIS DRAWING IS THE
CONFIDENTIAL PROPERTY OF SIKA
LIMITED AND MUST NOT BE
REPRODUCED EITHER WHOLLY OR
PARTLY. ALL RIGHTS IN RESPECT OF
PATENTS, DESIGN AND COPYRIGHTS
ARE RESERVED. SIKA LTD.
WWW.SIKA.CO.UK



Drawn by <i>A. O'Ferrall</i>	Checked by <i>D. Cliff</i>	Approved by <i>A. Burman</i>	Date 24/11/17
Description SIKAPROOF A LIFT PIT (OPTION 2)			
Drawing No. SPA08		Issue A	Sheet 1 / 1

SIKAPROOF A PIPE THROUGH RC SLAB

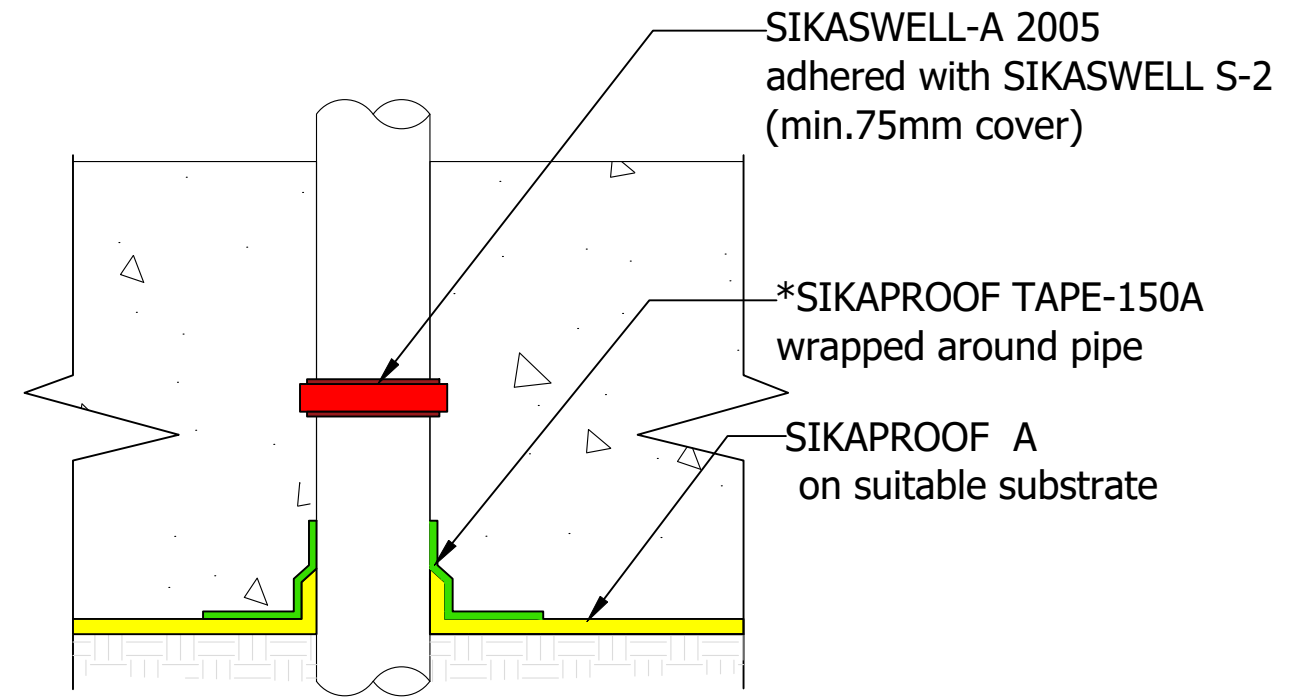
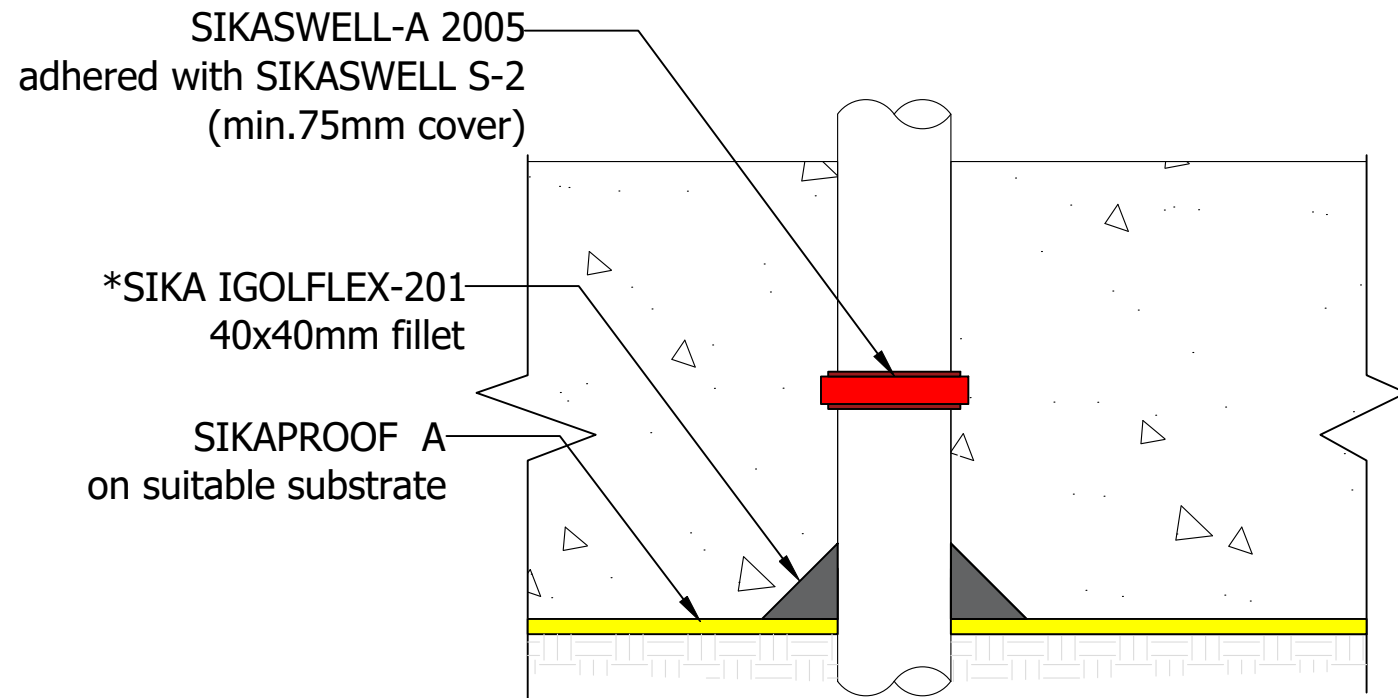

*ALTERNATIVE SEALING METHOD

The information contained herein and any other advice are given in good faith based on Sika's current knowledge and experience of the products when properly stored, handled and applied under normal conditions in accordance with Sika's recommendations. The information only applies to the application(s) and product(s) expressly referred to herein and is based on laboratory tests which do not replace practical tests. In case of changes in the parameters of the application, such as changes in substrates etc., or in case of a different application, consult Sika's Technical Service prior to using Sika products. The information contained herein does not relieve the user of the products from testing them for the intended application and purpose. All orders are accepted subject to our current terms of sale and delivery. Users must always refer to the most recent issue of the local Product Data Sheet for the product concerned, copies of which will be supplied on request.

**ALL DIMENSIONS ARE IN MM
UNLESS STATED
DO NOT SCALE FROM
DRAWING**

THIS DRAWING IS THE
CONFIDENTIAL PROPERTY OF SIKALIMITED AND MUST NOT BE
REPRODUCED EITHER WHOLLY OR
PARTLY. ALL RIGHTS IN RESPECT OF
PATENTS, DESIGN AND COPYRIGHTS
ARE RESERVED. SIKALTD.
WWW.SIKA.CO.UK



Drawn by <i>A. O'Ferrall</i>	Checked by <i>D. Cliff</i>	Approved by <i>A. Burman</i>	Date 24/11/17
Description SIKAPROOF A PIPE THROUGH RC SLAB			
Drawing No. SPA09		Issue A	Sheet 1 / 1